

Elite Screens -Saker Tab-Tension CLR Series Dimension Table

Unit: mm																	Packing dimension					
Models	Screen Diag. & Aspec Ratio	Case L(A)	View W (A1)	ceiling bracket hole distance (A2)	Screen W (A3)	A4 Reserved L/R width(without black painting) (预留黑边)	Weight Bar L (A5)	Overall H with ceiling Bracket (B)	View H(B1)	Screen H(B2)	Top black masking (B3)	Bottom black masking (B4)	End cap H with bracket (B5)	End cap W with ceiling bracket (C)	End cap H with ceiling bracket (C1)	Screen Material to Wall Distance (C2)	Weight bar diameter (C3)	N.W (KGS)	G.W (KGS)	L	W	H
SKT100XH-CLR-E12	100*(16:9)	2581	2214	1781	2300	25	2501	1730	1245	1605	305	55	118	118	125	35	23	18,34	25,52	2796	213	196
SKT120XH-CLR-E12	120*(16:9)	3044	2657	2244	2743	25	2964	1979	1494	1854	305	55	118	118	125	35	23	21,64	29,66	3266	215	195

Unit: Inches																	N.W (IBS)	G.W (IBS)	L (inch)	W (inch)	H (inch)	
SKT100XH-CLR-E12	100*(16:9)	101.6	87.2	70.1	90.6	1.0	98.5	68.1	49.0	63.2	12.0	2.2	4.6	4.6	4.9	1.4	0.9	40.43	56.26	110.08	8.39	7.72
SKT120XH-CLR-E12	120*(16:9)	119.8	104.6	88.3	108.0	1.0	116.7	77.9	58.8	73.0	12.0	2.2	4.6	4.6	4.9	1.4	0.9	47.71	65.39	128.58	8.46	7.68

Note: Data Error be ±1"

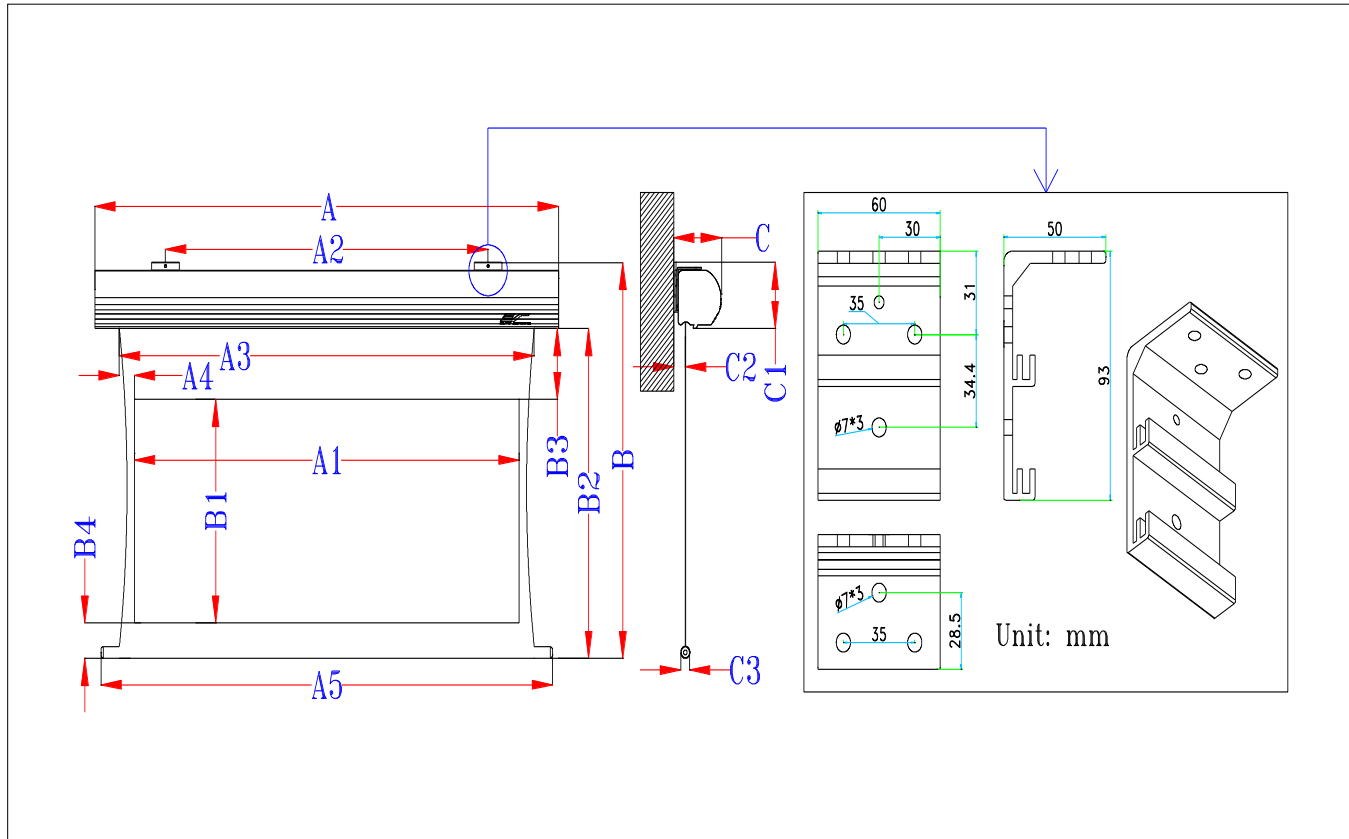

Elite Screens -Saker Tab-Tension Series Dimension Table

Unit: mm																		Packing dimension				
Models	Screen Diag. & Aspec Ratio	Case L(A)	View W (A1)	ceiling bracket hole distance (A2)	Screen W (A3)	L/R black masking (A4)	Weight Bar L (A5)	Overall H with ceiling Bracket (B)	View H(B1)	Screen H(B2)	Top black masking (B3)	Bottom black masking (B4)	End cap W with ceiling bracket (C)	End cap H with ceiling bracket (C1)	Screen Material to Wall Distance (C2)	Weight bar diameter (C3)	N.W (KGS)	G.W (KGS)	L	W	H	
SKT84XHW-E12	84"(16:9)	2285	1860	1485	2060	100	2220	1519	1046	1411	305	60	102	108	35	23	10,60	14,32	2456	170	162	
SKT84XHW-E24	84"(16:9)	2285	1860	1485	2060	100	2220	1824	1046	1716	610	60	102	108	35	23	11,00	14,66	2456	185	170	
SKT92XHW-E24	92"(16:9)	2453	2037	1653	2237	100	2388	1924	1146	1816	610	60	102	108	35	23	12,60	15,90	2650	170	160	
SKT100XHW-E12	100"(16:9)	2640	2214	1840	2414	100	2575	1718	1245	1610	305	60	102	108	35	23	12,30	16,16	2811	180	165	
SKT100XHW-E24	100"(16:9)	2640	2214	1840	2414	100	2575	2023	1245	1915	610	60	102	108	35	23	12,61	16,23	2811	182	165	
SKT110XHW-E12	110"(16:9)	2905	2435	2105	2675	120	2840	1843	1370	1735	305	60	102	108	35	23	14,66	18,92	3076	179	160	
SKT110XHW-E24	110"(16:9)	2905	2435	2105	2675	120	2840	2148	1370	2040	610	60	102	108	35	23	15,10	19,08	3080	195	170	
SKT120XHW-E10	120"(16:9)	3125	2657	2325	2897	120	3060	1916	1494	1808	254	60	102	108	35	23	14,98	19,58	3296	180	165	
SKT120XHW-E20	120"(16:9)	3125	2657	2325	2897	120	3060	2170	1494	2062	508	60	102	108	35	23	15,84	20,42	3300	170	180	
SKT135XHW-E6	135"(16:9)	3495	2989	2695	3229	120	3430	2001	1681	1893	152	60	102	108	35	23	17,17	21,83	3666	185	165	
SKT100XVW-E10	100"(4:3)	2453	2032	1653	2272	120	2388	1946	1524	1838	254	60	102	108	35	23	13,60	17,56	2605	170	160	
SKT100XVW-E24	100"(4:3)	2453	2032	1653	2272	120	2388	2302	1524	2194	610	60	102	108	35	23						
SKT120XVW-E9	120"(4:3)	2905	2438	2105	2678	120	2840	2226	1829	2118	229	60	102	108	35	23	15,44	19,64	3095	180	166	
SKT100NXW-E12	100"(16:10)	2580	2154	1780	2394	120	2515	1819	1346	1711	305	60	102	108	35	23	12,70	16,40	2751	180	160	
SKT100NXW-E24	100"(16:10)	2580	2154	1780	2394	120	2515	2124	1346	2016	610	60	102	108	35	23	13,26	17,06	2751	160	150	
SKT106NXW-E12	106"(16:10)	2705	2283	1905	2483	100	2640	1900	1427	1792	305	60	102	108	35	23	13,20	17,10	2880	180	170	
SKT110NXW-E10	110"(16:10)	2795	2369	1995	2569	100	2730	1903	1481	1795	254	60	102	108	35	23	13,96	17,92	2965	185	170	
SKT120NXW-E12	120"(16:10)	3050	2585	2250	2825	120	2985	2088	1615	1980	305	60	102	108	35	23	16,00	20,20	3220	185	170	
SKT100UH-E12-AUHD	100"(16:9)	2640	2214	1840	2454	120	2575	1718	1245	1610	305	60	102	108	35	23	13,10	16,80	2886	210	190	
SKT100UH-E24-AUHD	100"(16:9)	2640	2214	1840	2454	120	2575	2023	1245	1915	610	60	102	108	35	23	13,10	16,80	2886	210	190	
SKT110UH-E12-AUHD	110"(16:9)	2905	2435	2105	2675	120	2840	1843	1370	1735	305	60	102	108	35	23	14,30	18,09	3076	190	170	
SKT110UH-E24-AUHD	110"(16:9)	2905	2435	2105	2675	120	2840	2148	1370	2040	610	60	102	108	35	23	14,58	18,50	3076	185	155	
SKT120UH-E10-AUHD	120"(16:9)	3125	2657	2325	2897	120	3060	1916	1494	1808	254	60	102	108	35	23	16,24	21,68	3315	190	170	
SKT120UH-E20-AUHD	120"(16:9)	3125	2657	2325	2897	120	3060	2170	1494	2062	508	60	102	108	35	23	16,18	20,44	3296	180	160	
SKT100UH-E24-AUHD	100"(16:9)	2640	2214	1840	2454	120	2575	2023	1245	1915	610	60	102	108	35	23	13,22	17,18	2814	183	168	
SKT110UH-E24-AUHD	110"(16:9)	2905	2435	2105	2675	120	2840	2148	1370	2040	610	60	102	108	35	23	14,56	18,48	3055	180	160	
Unit: Inch																		N.W (IBS)	G.W (IBS)	L (inch)	W (inch)	H (inch)
SKT84XHW-E12	84"(16:9)	90,0	73,2	58,5	81,1	3,9	87,4	59,8	41,2	55,6	12,0	2,4	4,0	4,3	1,4	0,9	23,37	31,57	96,69	6,69	6,38	
SKT84XHW-E24	84"(16:9)	90,0	73,2	58,5	81,1	3,9	87,4	71,8	41,2	67,6	24,0	2,4	4,0	4,3	1,4	0,9	24,25	32,32	96,69	7,28	6,69	
SKT92XHW-E24	92"(16:9)	96,6	80,2	65,1	88,1	3,9	94,0	75,7	45,1	71,5	24,0	2,4	4,0	4,3	1,4	0,9	27,78	35,05	104,33	6,69	6,30	
SKT100XHW-E12	100"(16:9)	103,9	87,2	72,4	95,0	3,9	101,4	67,6	49,0	63,4	12,0	2,4	4,0	4,3	1,4	0,9	27,12	35,63	110,67	7,09	6,50	
SKT100XHW-E24	100"(16:9)	103,9	87,2	72,4	95,0	3,9	101,4	79,6	49,0	75,4	24,0	2,4	4,0	4,3	1,4	0,9	27,80	35,78	110,67	7,17	6,50	
SKT110XHW-E12	110"(16:9)	114,4	95,9	82,9	105,3	4,7	111,8	72,6	53,9	68,3	12,0	2,4	4,0	4,3	1,4	0,9	32,32	41,71	121,10	7,05	6,30	
SKT110XHW-E24	110"(16:9)	114,4	95,9	82,9	105,3	4,7	111,8	84,6	53,9	80,3	24,0	2,4	4,0	4,3	1,4	0,9	33,29	42,06	121,26	7,68	6,69	
SKT120XHW-E10	120"(16:9)	123,0	104,6	91,5	114,1	4,7	120,5	75,4	58,8	71,2	10,0	2,4	4,0	4,3	1,4	0,9	33,03	43,17	129,76	7,09	6,50	
SKT120XHW-E20	120"(16:9)	123,0	104,6	91,5	114,1	4,7	120,5	85,4	58,8	81,2	20,0	2,4	4,0	4,3	1,4	0,9	34,92	45,02	129,92	6,69	7,09	
SKT135XHW-E6	135"(16:9)	137,6	117,7	106,1	127,1	4,7	135,0	78,8	66,2	74,5	6,0	2,4	4,0	4,3	1,4	0,9	37,85	48,13	144,33	7,28	6,50	
SKT100XVW-E10	100"(4:3)	96,6	80,0	65,1	89,4	4,7	94,0	76,6	60,0	72,4	10,0	2,4	4,0	4,3	1,4	0,9	29,98	38,71	102,56	6,69	6,30	
SKT100XVW-E24	100"(4:3)	96,6	80,0	65,1	89,4	4,7	94,0	90,6	60,0	86,4	24,0	2,4	4,0	4,3	1,4	0,9	0,00	0,00	0,00	0,00	0,00	
SKT120XVW-E9	120"(4:3)	114,4	96,0	82,9	105,4	4,7	111,8	87,6	72,0	83,4	9,0	2,4	4,0	4,3	1,4	0,9	34,04	43,30	121,85	7,09	6,54	
SKT100NXW-E12	100"(16:10)	101,6	84,8	70,1	94,3	4,7	99,0	71,6	53,0	67,4	12,0	2,4	4,0	4,3	1,4	0,9	28,00	36,16	108,31	7,09	6,30	
SKT100NXW-E24	100"(16:10)	101,6	84,8	70,1	94,3	4,7	99,0	83,6	53,0	79,4	24,0	2,4	4,0	4,3	1,4	0,9	29,23	37,61	108,31	6,30	5,91	
SKT106NXW-E12	106"(16:10)	106,5	89,9	75,0	97,8	3,9	103,9	74,8	56,2	70,6	12,0	2,4	4,0	4,3	1,4	0,9	29,10	37,70	113,39	7,09	6,69	
SKT110NXW-E10	110"(16:10)	110,0	93,3	78,5	101,1	3,9	107,5	74,9	58,3	70,7	10,0	2,4	4,0	4,3	1,4	0,9	30,78	39,51	116,73	7,28	6,69	
SKT120NXW-E12	120"(16:10)	120,1	101,8	88,6	111,2	4,7	117,5	82,2	63,6	78,0	12,0	2,4	4,0	4,3	1,4	0,9	35,27	44,53	126,77	7,28	6,69	
SKT100UH-E12-AUHD	100"(16:9)	103,9	87,2	72,4	96,6	4,7	101,4	67,6	49,0	63,4	12,0	2,4	4,0	4,3	1,4	0,9	28,88	37,04	113,62	8,27	7,48	
SKT100UH-E24-AUHD	100"(16:9)	103,9	87,2	72,4	96,6	4,7	101,4	79,6	49,0	75,4	24,0	2,4	4,0	4,3	1,4	0,9	28,88	37,04	113,62	8,27	7,48	
SKT110UH-E12-AUHD	110"(16:9)	114,4	95,9	82,9	105,3	4,7	111,8	72,6	53,9	68,3	12,0	2,4	4,0	4,3	1,4	0,9	31,53	39,88	121,10	7,48	6,69	
SKT110UH-E24-AUHD	110"(16:9)	114,4	95,9	82,9	105,3	4,7	111,8	84,6	53,9	80,3	24,0	2,4	4,0	4,3	1,4	0,9	32,14	40,79	121,10	7,28	6,10	
SKT120UH-E10-AUHD	120"(16:9)	123,0	104,6	91,5	114,1	4,7	120,5	75,4	58,8	71,2	10,0	2,4	4,0	4,3	1,4	0,9	35,80	47,80	130,51	7,48	6,69	
SKT120UH-E20-AUHD	120"(16:9)	123,0	104,6	91,5	114,1	4,7	120,5	85,4	58,8	81,2	20,0	2,4	4,0	4,3	1,4	0,9	35,67	45,06	129,76	7,09	6,30	
SKT100UH-E24-AUHD	100"(16:9)	103,9	87,2	72,4	96,6	4,7	101,4	79,6	49,0	75,4	24,0	2,4	4,0	4,3	1,4	0,9	29,15	37,88	110,79	7,20	6,61	
SKT110UH-E24-AUHD	110"(16:9)	114,4	95,9	82,9	105,3	4,7	111,8	84,6	53,9	80,3	24,0	2,4	4,0	4,3	1,4	0,9	32,10	40,74	120,28	7,09	6,30	

Note: Data Error be $\pm 1''$

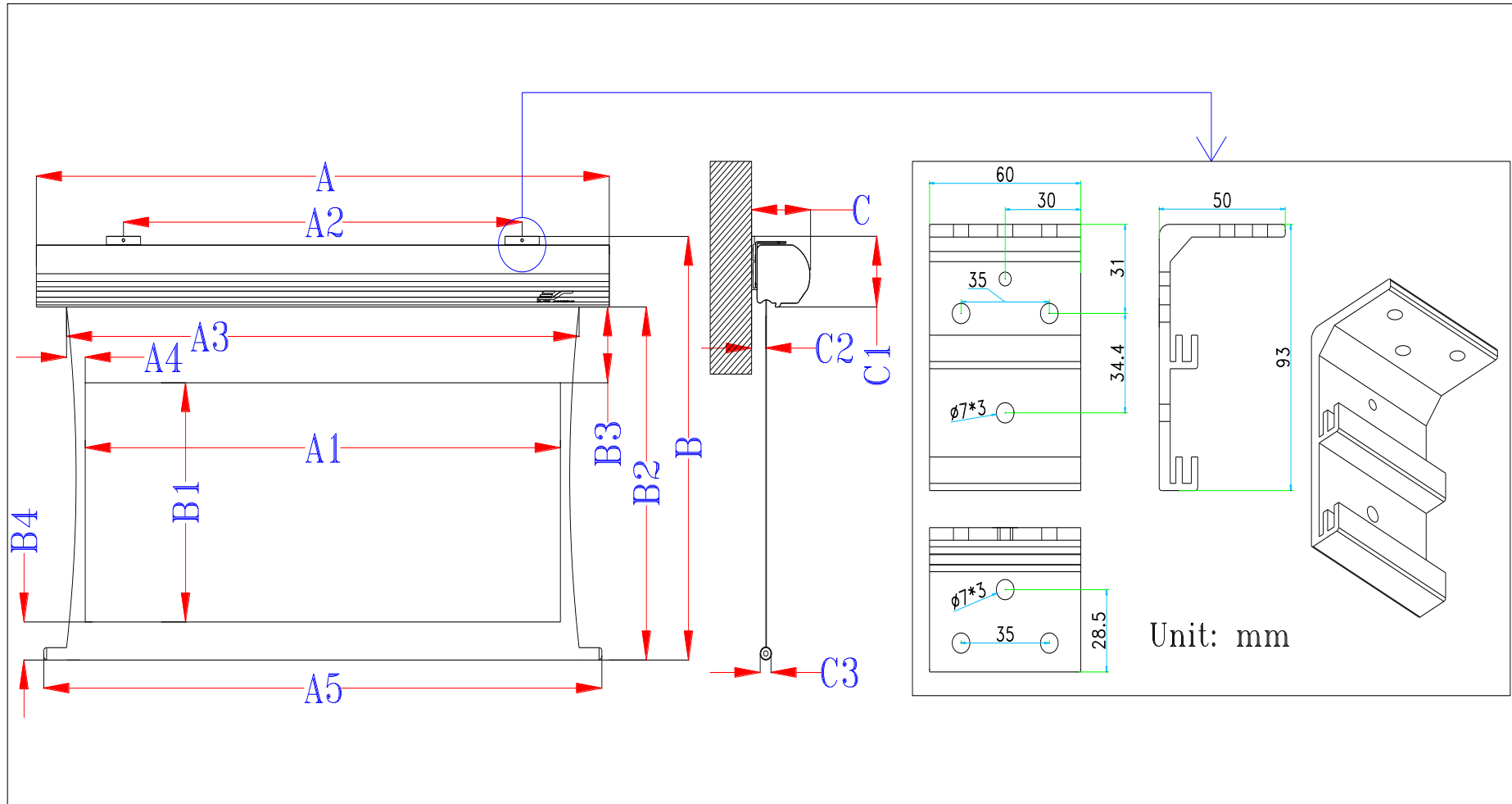

Elite Screens -Saker Tab-Tension Series Dimension Table (Large Case)

Unit: mm																				Packing dimension				
Models	Screen Diag. & Aspect Ratio	Case L(A)	View W (A1)	ceiling bracket hole distance (A2)	Screen W (A3)	L/R black masking (A4)	Weight Bar L (A5)	Overall H with ceiling Bracket (B)	View H(B1)	Screen H(B2)	Top black masking (B3)	Bottom black masking (B4)	End cap H with bracket (B5)	End cap W with ceiling bracket (C)	End cap H with ceiling bracket (C1)	Screen Material to Wall Distance (C2)	Weight bar diameter (C3)	N.W (KGS)	G.W (KGS)	L	W	H		
SKT135XHW2-E6	135*(16:9)	3487	2989	2687	3209	110	3427	2018	1681	1893	152	60	118	118	125	35	23							
SKT135XHW2-E10	135*(16:9)	3487	2989	2687	3209	110	3427	2120	1681	1995	254	60	118	118	125	35	23	23.68	31.10	3632	212	200		
SKT135XHW2-E12	135*(16:9)	3487	2989	2687	3209	110	3427	2171	1681	2046	305	60	118	118	125	35	23	23.48	30.58	3681	205	190		
SKT135XHW2-E24	135*(16:9)	3487	2989	2687	3249	130	3427	2476	1681	2351	610	60	118	118	125	35	23	24.90	32.60	3710	210	200		
SKT150XHW2-E6	150*(16:9)	3819	3321	3019	3541	110	3759	2205	1868	2080	152	60	118	118	125	35	23	25.80	32.92	4013	208	195		
SKT150XHW2-E12	150*(16:9)	3819	3321	3019	3561	120	3759	2358	1868	2233	305	60	118	118	125	35	23	28.10	36.10	4040	215	200		
SKT150XHW2-E24	150*(16:9)	3819	3321	3019	3591	135	3759	2663	1868	2538	610	60	118	118	125	35	23	27.32	34.46	4013	200	190		
SKT165XHW2-E6	165*(16:9)	4156	3653	3356	3893	120	4096	2392	2055	2267	152	60	118	118	125	35	23	30.48	40.20	4310	210	200		
SKT165XHW2-E12	165*(16:9)	4156	3653	3356	3913	130	4096	2545	2055	2420	305	60	118	118	125	35	23							
SKT165XHW2-E20	165*(16:9)	4156	3653	3356	3943	145	4096	2748	2055	2623	508	60	118	118	125	35	23	29.28	37.12	4275	210	200		
SKT180XHW2-E6	180*(16:9)	4483	3985	3683	4245	130	4423	2579	2242	2454	152	60	118	118	125	35	23	31.20	39.78	4677	207	192		
SKT180XHW2-E12	180*(16:9)	4483	3985	3683	4275	145	4423	2732	2242	2607	305	60	118	118	125	35	23							
SKT135XVW2-E5	135*(4:3)	3271	2743	2471	2983	120	3211	2369	2057	2244	127	60	118	118	125	35	23							
SKT135XVW2-E12	135*(4:3)	3271	2743	2471	3003	130	3211	2547	2057	2422	305	60	118	118	125	35	23							
SKT135XVW2-E24	135*(4:3)	3271	2743	2471	3043	150	3211	2852	2057	2727	610	60	118	118	125	35	23							
SKT150XVW2-E6	150*(4:3)	3546	3048	2746	3318	135	3486	2623	2286	2498	152	60	118	118	125	35	23							
SKT150XVW2-E10	150*(4:3)	3546	3048	2746	3338	145	3486	2725	2286	2600	254	60	118	118	125	35	23							
SKT135NXW2-E4	135*(16:10)	3406	2908	2606	3128	110	3346	2104	1817	1979	102	60	118	118	125	35	23							
SKT135NXW2-E6	135*(16:10)	3406	2908	2606	3128	110	3346	2154	1817	2029	152	60	118	118	125	35	23							
SKT135NXW2-E12	135*(16:10)	3406	2908	2606	3148	120	3346	2307	1817	2182	305	60	118	118	125	35	23	22.58	28.94	3545	210	200		
SKT135NXW2-E24	135*(16:10)	3406	2908	2606	3178	135	3346	2612	1817	2487	610	60	118	118	125	35	23	23.08	29.52	3543	205	195		
SKT150NXW2-E6	150*(16:10)	3729	3231	2929	3471	120	3669	2356	2019	2231	152	60	118	118	125	35	23	25.78	32.50	3848	207	195		
SKT150NXW2-E12	150*(16:10)	3729	3231	2929	3491	130	3669	2509	2019	2384	305	60	118	118	125	35	23							
SKT150NXW2-E20	150*(16:10)	3729	3231	2929	3521	145	3669	2712	2019	2587	508	60	118	118	125	35	23	20.84	27.54	3845	205	195		
SKT165NXW2-E6	165*(16:10)	4086	3554	3286	3814	130	4026	2558	2221	2433	152	60	118	118	125	35	23	31.38	35.12	4177	210	190		
SKT165NXW2-E12	165*(16:10)	4086	3554	3286	3844	145	4026	2711	2221	2586	305	60	118	118	125	35	23							
SKT180NXW2-E8	180*(16:10)	4416	3877	3616	4177	150	4356	2811	2423	2686	203	60	118	118	125	35	23	31.26	39.06	4490	205	195		
SKT135UH-E12-AUHD	135*(16:9)	3487	2989	2687	3289	150	3427	2171	1681	2046	305	60	118	118	125	35	23	23.24	29.70	3681	200	190		
SKT150UH-E12-AUHD	150*(16:9)	3819	3321	3019	3621	150	3759	2358	1868	2233	305	60	118	118	125	35	23	25.62	32.56	3938	200	190		
SKT180UH-E3-AUHD	180*(16:9)	4483	3985	3683	4285	150	4423	2503	2242	2378	76	60	118	118	125	35	23	29.98	38.58	4677	200	190		
SKT92UHD5-E12	92*(16:9)	2516	2037	1716	2337	150	2456	1636	1146	1511	305	60	118	118	125	35	23	18.10	24.50	2740	210	200		
SKT92XHD5-E12	92*(16:9)	2516	2037	1716	2337	150	2456	1636	1146	1511	305	60	118	118	125	35	23	18.10	24.50	2740	210	200		
SKT100UHD5-E12	100*(16:9)	2692	2214	1892	2514	150	2632	1735	1245	1610	305	60	118	118	125	35	23	19.70	26.30	2920	210	200		
SKT100XHD5-E12	100*(16:9)	2692	2214	1892	2514	150	2632	1735	1245	1610	305	60	118	118	125	35	23	20.36	28.30	2886	215	200		
SKT110UHD5-E12	110*(16:9)	2933	2435	2133	2735	150	2873	1860	1370	1735	305	60	118	118	125	35	23	21.12	28.88	3127	215	195		
SKT110XHD5-E12	110*(16:9)	2933	2435	2133	2735	150	2873	1860	1370	1735	305	60	118	118	125	35	23	21.12	28.88	3127	215	195		
SKT120UHD5-E12	120*(16:9)	3155	2657	2355	2957	150	3095	1984	1494	1859	305	60	118	118	125	35	23	23.01	31.05	3394	215	195		
SKT120XHD5-E12	120*(16:9)	3155	2657	2355	2957	150	3095	1984	1494	1859	305	60	118	118	125	35	23	23.01	31.05	3394	215	195		
SKT135UHD5-E10	135*(16:9)	3487	2989	2687	3289	150	3427	2120	1681	1995	254	60	118	118	125	35	23	25.50	33.05	3710	210	200		
SKT135XHD5-E10	135*(16:9)	3487	2989	2687	3289	150	3427	2120	1681	1995	254	60	118	118	125	35	23	25.50	33.05	3710	210	200		
SKT150XHD5-E6	150*(16:9)	3819	3321	3019	3621	150	3759	2205	1868	2080	152	60	118	118	125	35	23	28.98	39.40	4013	215	200		
Unit: Inch																		N.W (IBS)	G.W (IBS)	L (inch)	W (inch)	H (inch)		
SKT135XHW2-E6	135*(16:9)	137.3	117.7	105.8	126.3	4.3	134.9	79.4	66.2	74.5	6.0	2.4	4.6	4.6	4.9	1.4	0.9	0.00	0.00	0.00	0.00	0.00		
SKT135XHW2-E10	135*(16:9)	137.3	117.7	105.8	126.3	4.3	134.9	83.5	66.2	78.5	10.0	2.4	4.6	4.6	4.9	1.4	0.9	52.21	68.56	142.99	8.35	7.87		
SKT135XHW2-E12	135*(16:9)	137.3	117.7	105.8	126.3	4.3	134.9	85.5	66.2	80.6	12.0	2.4	4.6	4.6	4.9	1.4	0.9	51.76	67.42	144.92	8.07	7.48		
SKT135XHW2-E24	135*(16:9)	137.3	117.7	105.8	127.9	5.1	134.9	97.5	66.2	92.6	24.0	2.4	4.6	4.6	4.9	1.4	0.9	54.90	71.87	146.06	8.27	7.87		
SKT150XHW2-E6	150*(16:9)	150.4	130.7	118.9	139.4	4.3	148.0	86.8	73.5	81.9	6.0	2.4	4.6	4.6	4.9	1.4	0.9	56.88	72.58	157.99	8.19	7.68		
SKT150XHW2-E12	150*(16:9)	150.4	130.7	118.9	140.2	4.7	148.0	92.8	73.5	87.9	12.0	2.4	4.6	4.6	4.9	1.4	0.9	61.95	79.59	159.06	8.46	7.87		
SKT150XHW2-E24	150*(16:9)	150.4	130.7	118.9	141.4	5.3	148.0	104.8	73.5	99.9	24.0	2.4	4.6	4.6	4.9	1.4	0.9	60.23	75.97	157.99	7.87	7.48		
SKT165XHW2-E6	165*(16:9)	163.6	143.8	132.1	153.3	4.7	161.3	94.2	80.9	89.3	6.0	2.4	4.6	4.6	4.9	1.4	0.9	67.20	88.63	169.69	8.27	7.87		
SKT165XHW2-E12	165*(16:9)	163.6	143.8	132.1	154.1	5.1	161.3	100.2	80.9	95.3	12.0	2.4	4.6	4.6	4.9	1.4	0.9	0.00	0.00	0.00	0.00	0.00		
SKT165XHW2-E20	165*(16:9)	163.6	143.8	132.1	155.2	5.7	161.3	108.2	80.9	103.3	20.0	2.4	4.6	4.6	4.9	1.4	0.9	64.55	81.84	168.31	8.27	7.87		
SKT180XHW2-E6	180*(16:9)	176.5	156.9	145.0	167.1	5.1	174.1	101.5	88.3	96.6	6.0	2.4	4.6	4.6	4.9	1.4	0.9	68.78	87.70	184.13	8.15	7.56		
SKT180XHW2-E12	180*(16:9)	176.5	156.9	145.0	168.3	5.7	174.1	107.6	88.3	102.6	12.0	2.4	4.6	4.6	4.9	1.4	0.9	0.00	0.00	0.00	0.00	0.00		
SKT135XVW2-E5	135*(4:3)	128.8	108.0	97.3	117.4	4.7	126.4	93.3	81.0	88.3	5.0	2.4	4.6	4.6	4.9	1.4	0.9	0.00	0.00	0.00	0.00	0.00		
SKT135XVW2-E12	135*(4:3)	128.8	108.0	97.3	118.2	5.1	126.4	100.3	81.0	95.4	12.0	2.4	4.6	4.6	4.9	1.4	0.9	0.00	0.00	0.00	0.00	0.00		
SKT135XVW2-E24	135*(4:3)	128.8	108.0	97.3	119.8	5.9	126.4	112.3	81.0	107.4	24.0	2.4	4.6	4.6	4.9	1.4	0.9	0.00	0.00	0.00	0.00	0.00		
SKT150XVW2-E6	150*(4:3)	139.6	120.0	108.1	130.6	5.3	137.2	103.3	90.0	98.3	6.0	2.4	4.6	4.6	4.9	1.4	0.9	0.00	0.00					

SKT150NXW2-E6	150° (16:10)	146,8	127,2	115,3	136,7	4,7	144,4	92,8	79,5	87,8	6,0	2,4	4,6	4,6	4,9	1,4	0,9	56,84	71,65	151,50	8,15	7,68
SKT150NXW2-E12	150° (16:10)	146,8	127,2	115,3	137,4	5,1	144,4	98,8	79,5	93,9	12,0	2,4	4,6	4,6	4,9	1,4	0,9	0,00	0,00	0,00	0,00	0,00
SKT150NXW2-E20	150° (16:10)	146,8	127,2	115,3	138,6	5,7	144,4	106,8	79,5	101,9	20,0	2,4	4,6	4,6	4,9	1,4	0,9	45,94	60,72	151,38	8,07	7,68
SKT165NXW2-E6	165° (16:10)	160,9	139,9	129,4	150,2	5,1	158,5	100,7	87,4	95,8	6,0	2,4	4,6	4,6	4,9	1,4	0,9	69,18	77,43	164,45	8,27	7,48
SKT165NXW2-E12	165° (16:10)	160,9	139,9	129,4	151,3	5,7	158,5	106,7	87,4	101,8	12,0	2,4	4,6	4,6	4,9	1,4	0,9	0,00	0,00	0,00	0,00	0,00
SKT165NXW2-E8	180° (16:10)	173,9	152,6	142,4	164,4	5,9	171,5	110,7	95,4	105,7	8,0	2,4	4,6	4,6	4,9	1,4	0,9	68,92	86,11	176,77	8,07	7,68
SKT135UH-E12-AUHD	135° (16:9)	137,3	117,7	105,8	129,5	5,9	134,9	85,5	66,2	80,6	12,0	2,4	4,6	4,6	4,9	1,4	0,9	51,24	65,48	144,92	7,87	7,48
SKT150UH-E12-AUHD	150° (16:9)	150,4	130,7	118,9	142,6	5,9	148,0	92,8	73,5	87,9	12,0	2,4	4,6	4,6	4,9	1,4	0,9	56,48	71,78	155,04	7,87	7,48
SKT180UH-E3-AUHD	180° (16:9)	176,5	156,9	145,0	168,7	5,9	174,1	98,5	88,3	93,6	3,0	2,4	4,6	4,6	4,9	1,4	0,9	66,09	85,05	184,13	7,87	7,48
SKT92UHD5-E12	92° (16:9)	99,1	80,2	67,6	92,0	5,9	96,7	64,4	45,1	59,5	12,0	2,4	4,6	4,6	4,9	1,4	0,9	39,90	54,01	107,87	8,27	7,87
SKT92XHD5-E12	92° (16:9)	99,1	80,2	67,6	92,0	5,9	96,7	64,4	45,1	59,5	12,0	2,4	4,6	4,6	4,9	1,4	0,9	39,90	54,01	107,87	8,27	7,87
SKT100UHD5-E12	100° (16:9)	106,0	87,2	74,5	99,0	5,9	103,6	68,3	49,0	63,4	12,0	2,4	4,6	4,6	4,9	1,4	0,9	43,43	57,98	114,96	8,27	7,87
SKT100XHD5-E12	100° (16:9)	106,0	87,2	74,5	99,0	5,9	103,6	68,3	49,0	63,4	12,0	2,4	4,6	4,6	4,9	1,4	0,9	44,89	62,39	113,62	8,46	7,87
SKT110UHD5-E12	110° (16:9)	115,5	95,9	84,0	107,7	5,9	113,1	73,2	53,9	68,3	12,0	2,4	4,6	4,6	4,9	1,4	0,9	46,56	63,67	123,11	8,46	7,68
SKT110XHD5-E12	110° (16:9)	115,5	95,9	84,0	107,7	5,9	113,1	73,2	53,9	68,3	12,0	2,4	4,6	4,6	4,9	1,4	0,9	46,56	63,67	123,11	8,46	7,68
SKT120UHD5-E12	120° (16:9)	124,2	104,6	92,7	116,4	5,9	121,9	78,1	58,8	73,2	12,0	2,4	4,6	4,6	4,9	1,4	0,9	50,73	68,45	133,62	8,46	7,68
SKT120XHD5-E12	120° (16:9)	124,2	104,6	92,7	116,4	5,9	121,9	78,1	58,8	73,2	12,0	2,4	4,6	4,6	4,9	1,4	0,9	50,73	68,45	133,62	8,46	7,68
SKT135UHD5-E10	135° (16:9)	137,3	117,7	105,8	129,5	5,9	134,9	83,5	66,2	78,5	10,0	2,4	4,6	4,6	4,9	1,4	0,9	56,22	72,86	146,06	8,27	7,87
SKT135XHD5-E10	135° (16:9)	137,3	117,7	105,8	129,5	5,9	134,9	83,5	66,2	78,5	10,0	2,4	4,6	4,6	4,9	1,4	0,9	56,22	72,86	146,06	8,27	7,87
SKT150XHD5-E6	150° (16:9)	150,4	130,7	118,9	142,6	5,9	148,0	86,8	73,5	81,9	6,0	2,4	4,6	4,6	4,9	1,4	0,9	63,89	86,86	157,99	8,46	7,87

Note: Data Error be ±1"

